

# 12V & 24V Motion Sensor

## Instruction manual

### Technical specifications:

- 12V Model: Input Voltage 12VDC. Current Draw at Standby: 6mA
- 24V Model: Input Voltage: 24VDC. Current Draw at Standby: 9mA
- Switching contact: Normally open. Contact Rating at 12V: 5A Max.
- Detecting Angle: 120° elliptical field of view up to a distance of 10 metres
- Timer: Adjustable ON TIME from about 6 sec. to 12 min.
- Lux: Adjustable "ambient light level" control.  
Sensing: About 5 LUX Upwards.
- Meter: Adjustable "Sensitivity" (Detecting range) of Sensor.
- Operating Temperature: - 20°C to +45°C

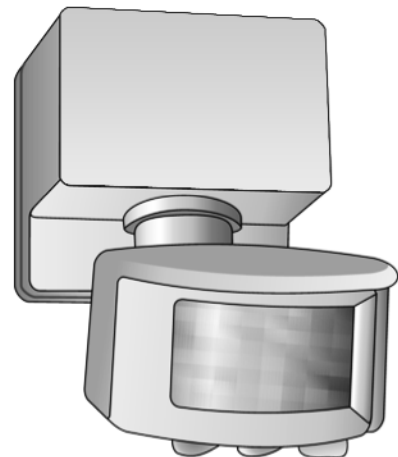

## 1. Selecting A Location

### How large an area will sensor detect?

When mounted at the recommended height of 2 to 3 metres, the detection pattern extends out about 6 to 10 metres and is 120° wide. To reduce coverage, aim the detector toward the ground.

### INFRARED COVERAGE AREA

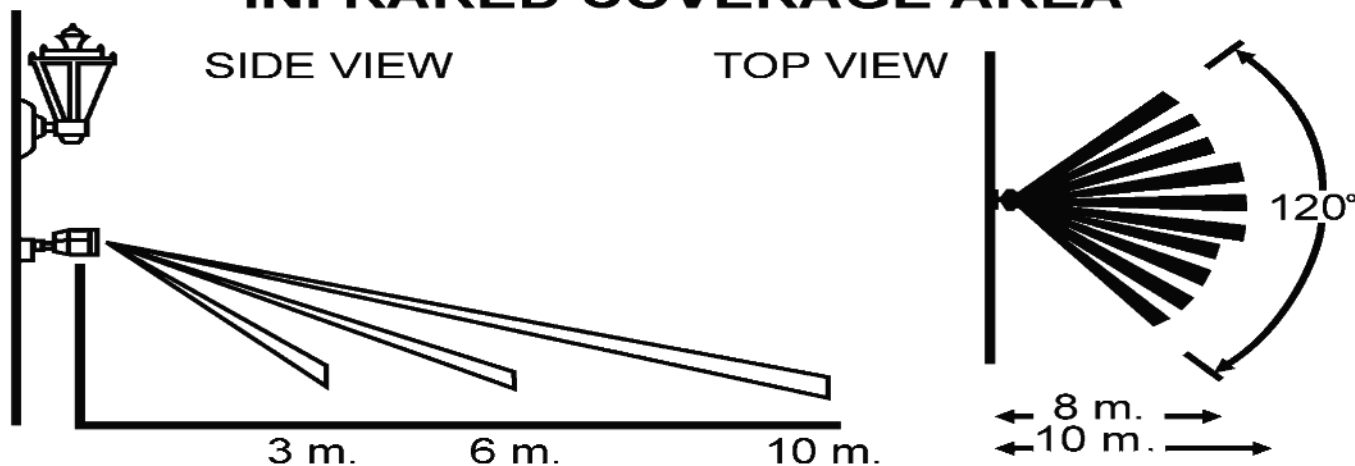

### Do Not Locate:

- On pole or tree that sways in wind. Movement triggers sensor.
- Where movement is directly toward sensor.

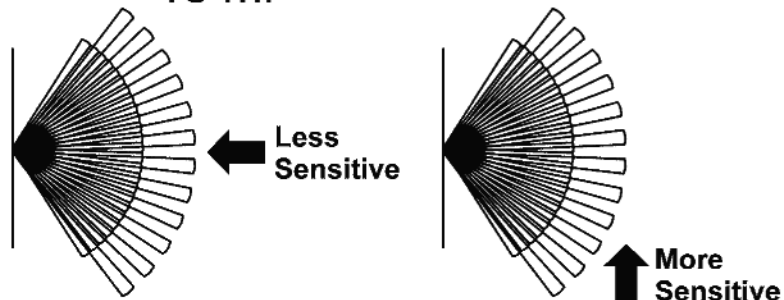

### To Avoid Nuisance Triggering

Your motion sensor may be activated by large animals, lights, reflective surfaces, heat sources, or movement of objects.

The following guidelines will help you avoid nuisance triggering.

- Do not aim the sensor toward lights of any kind.
- If installing the sensor in tandem with a light(s), mount the sensor module below the light(s).
- Avoid mounting the sensor near heat sources, such as heating vents, air conditioners, dryer vents or lights.
- Avoid aiming the sensor toward objects which may move in the wind, such as bushes or open air hanging ornaments.
- Avoid directing the sensor toward areas or objects whose surfaces are highly reflective or are subject to rapid temperature change. Such as pools.

Although the sensor is weather-resistant, locate it under cover so that driving rain or snow will not hit the lens of sensor.

## 2. Installing Your Motion Sensor

**Caution:** turn off all power by removing power fuse or turning off circuit breaker.

- Read entire instruction manual before proceeding.
- All wiring should comply with local electrical codes and may require a qualified electrician.
- The total lighting load connected to the Sensor must not exceed 10A load. Do not use to control motors or pumps.
- If you are replacing an existing outdoor light, turn off the power, disconnect and remove the old fixture.
- If there is no power, contact your supplier or Rainbow Power Company to install the required DC wiring.

### Install Procedure

- Fasten the box base rigidly to the selected mounting surface (Wall or Ceiling) with the cable entry hole facing downward. (see FIG A)
- Take Light & Power Cable through rubber grommet, then connect wires as per wiring diagram. (see FIG C)
- Knock out either of the holes for fitting the sensor onto the base (depending on whether it will be wall mounted or ceiling mounted). (FIG D).
- Fit terminal block onto pins and install the sensor, securing it onto the connection box with the plastic washer and metal nut provided.
- Re-check if the wire connection is correct.
- Cover base with sensor cover, then fix with 2 screws.

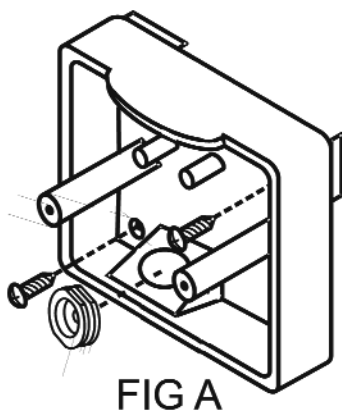

FIG A

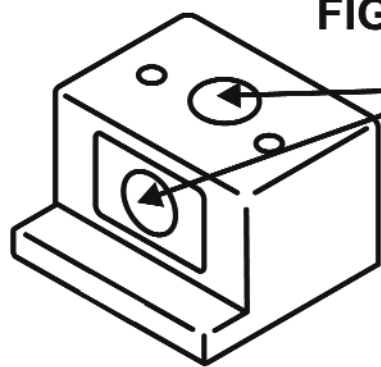

FIG. D

Knock hole  
for installation

CEILING MOUNTING

WALL MOUNT

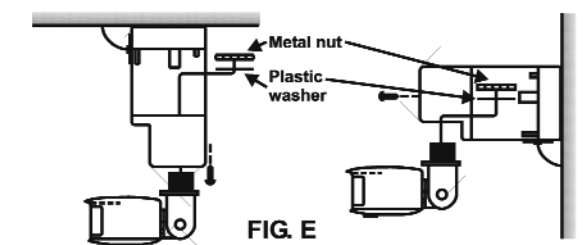

FIG. E

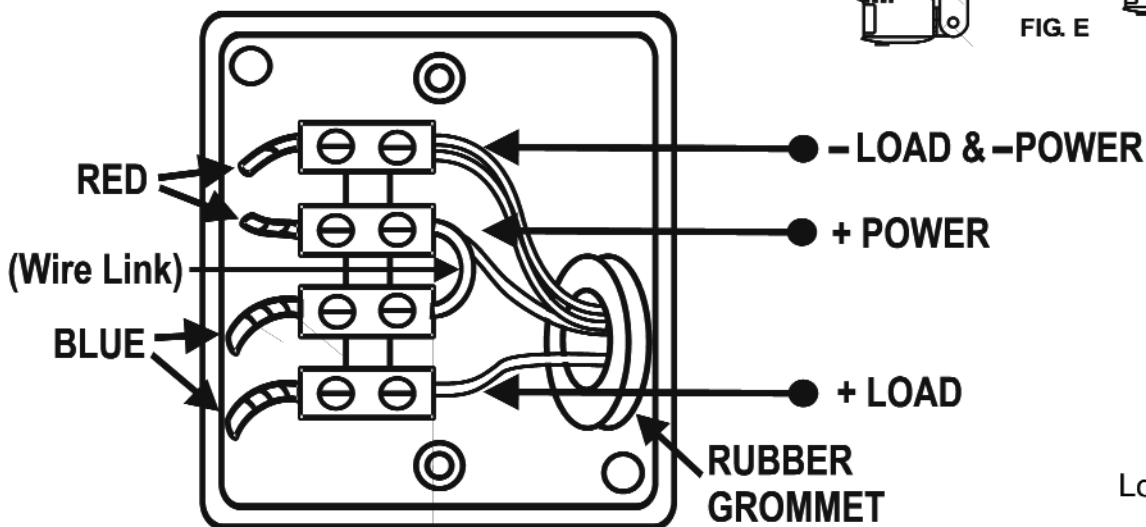

FIG. C

**Please Note:** This sensor can work from either 12 volts DC or 12 volts AC. Hence the power (red) and load (blue) internal wires are not marked for polarity.

### 3. Aiming And Adjustment

When power is applied to the sensor, it will start working in AUTO MODE. If you need to check and adjust the coverage pattern of sensor, following FIG.F, you can turn adjusting knob of TIME control to " - ", LUX control to ☼ + ☾, METER control to "+". Thereafter, you can do "WALK TEST" and the sensor will operate in any ambient light level and go off about 6 seconds after each detection.

1. Follow FIG. F – Start outside the pattern and walk across the pattern until the control unit go on and off, repeat it until you are satisfied with the coverage.
2. Eliminating unwanted detection. To mask a lens segment, use the black colour electric tape and cover only the lens segment which is viewing the potential problem area such as an open doorway. Caution must be observed so that the lens is not scratched or damaged, after properly masking a lens segment, recheck by walk testing for proper detection.

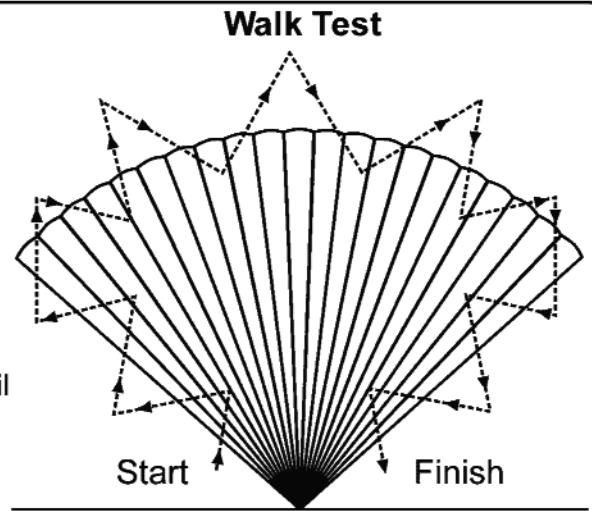

### 4. Normal Operation

Power switch of the sensor ON, the sensor will automatically turn into "AUTO" mode. This "AUTO" mode is for normal operation.

1. Set the "TIME" control. The minimum setting is about 6 secs. The maximum is about 12 minutes. This period starts after the movement in the detection coverage.
2. Set the "LUX" control. Turn adjusting knob to (☾). The device only operates during the period of darkness. Turn adjusting knob to (☼ + ☾), The device will operate in any degree of brightness.

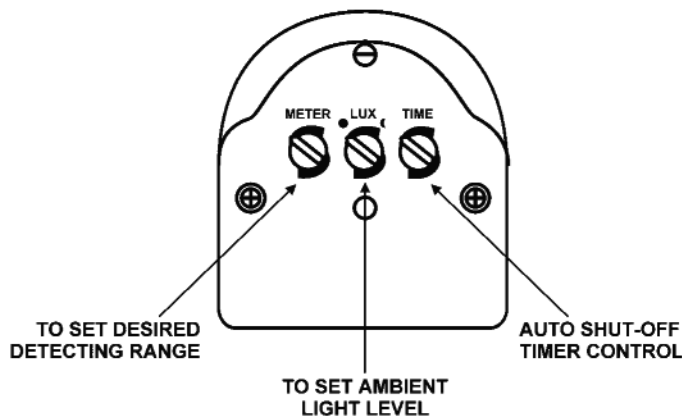

FIG F

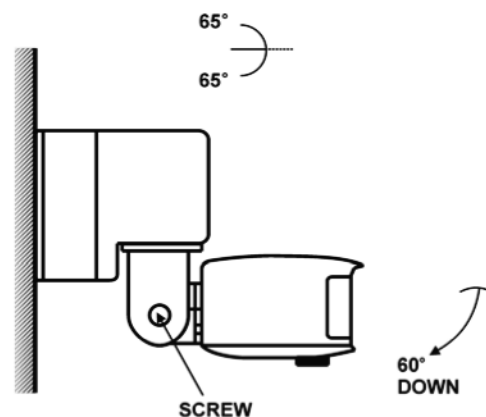

FIG G

Turning the switch OFF will turn off the sensor and the controlled unit. When switching the power switch ON, the sensor will automatically switch ON (in AUTOMATIC MODE) Leave the power switch ON, for normal operation. The sensor will either only switch the light on at night or the whole day – depending on the setting of the daylight sensor. (LUX)

#### Note:

- In **auto mode**, the timer remains on for about 6 seconds. But, when the object keeps moving in the detecting area, the timer will renew its counting time and not turn off until 6 seconds after the object stops moving.
- **Conditions which may cause lower sensitivity:**
  1. On very foggy nights sensitivity may be less due to moisture collecting on the lens.
  2. On very hot days sensitivity may be less since high ambient temperature and surrounding inanimate objects may be close to body temperature making the unit appear to be much less sensitive.
  3. On very cold days when heavy clothing is used, especially covering the facial area, very little heat will be emitted from the body causing the unit to appear less sensitive.
- **Cleaning** – Wipe with damp cloth, only. Soaps or polishes may damage the sensor lens.

## **5. Trouble-Shooting**

Each Sensor undergoes rigorous testing and quality control procedures before it leaves the factory. Malfunctions are most often due to incorrect installation or aiming of the unit. See Sections #1 & #3.

### **Lights do not turn on**

1. Turn off power for at least 5 seconds, then on again.
2. Check that bulbs and fixtures work and that there are no loose connections in the wiring. Compare wiring to the wiring diagram. Check that power is on.
3. Check that sensor is level from side to side and pointed at the area you desire.
4. Check that input voltage is not below 10.5V DC.

### **Lights Go On and Off Quickly**

1. Heat from the lights will cause unsteady sensor performance.
2. Make sure lights are not reflecting back into the sensor. Check for white or reflective surfaces in the protection pattern. Aim sensor and lights in different directions.
3. Note that the sensor is more sensitive in winter since infrared energy is easier for the sensor to detect in cold temperatures.

### **Lights Do Not Turn Off**

1. Check that the Time control knob on the bottom of the sensor is set to minimum.
2. Stay completely out of the protection pattern to avoid activating.
3. Make sure unit is not mounted on an unstable object (tree or pole) that sways in the wind. Make sure unit is firmly mounted.
4. Make sure unit is not aimed at something that would cause a temperature change such as free branches, a body of water, air conditioners or heating vents.

### **Lights Turn On In Storms**

Rain, snow and windstorms can create large temperature changes which may turn on the sensor. False triggering can be minimized by installing the sensor in a protected location and turning down the sensitivity control.

### **Maintenance and Repair**

Keep the lens area clean and free of obstructions. Do not attempt to open or repair the unit. There are no user serviceable parts. For repair service, contact your local dealer or Rainbow Power Company.